



max load weight: 4,000 lbs.
max load size: 50" x 50"



MACHINE FEATURES

- Forklift portable (either end, hp only)

Turntable system

- Welded heavy-duty reinforced structural steel construction for around-the-clock operation
- Powder coat finish that provides a durable scratch resistant surface and prevents corrosion
- 4 point caster support for HP turntable
- 8 point - Delrin caster support for LP turntable
- Turntable direct drive: 1/2 HP, DC motor with ANSI 50 chain
- Variable turntable speed (0-12 RPM)
- UL approved components

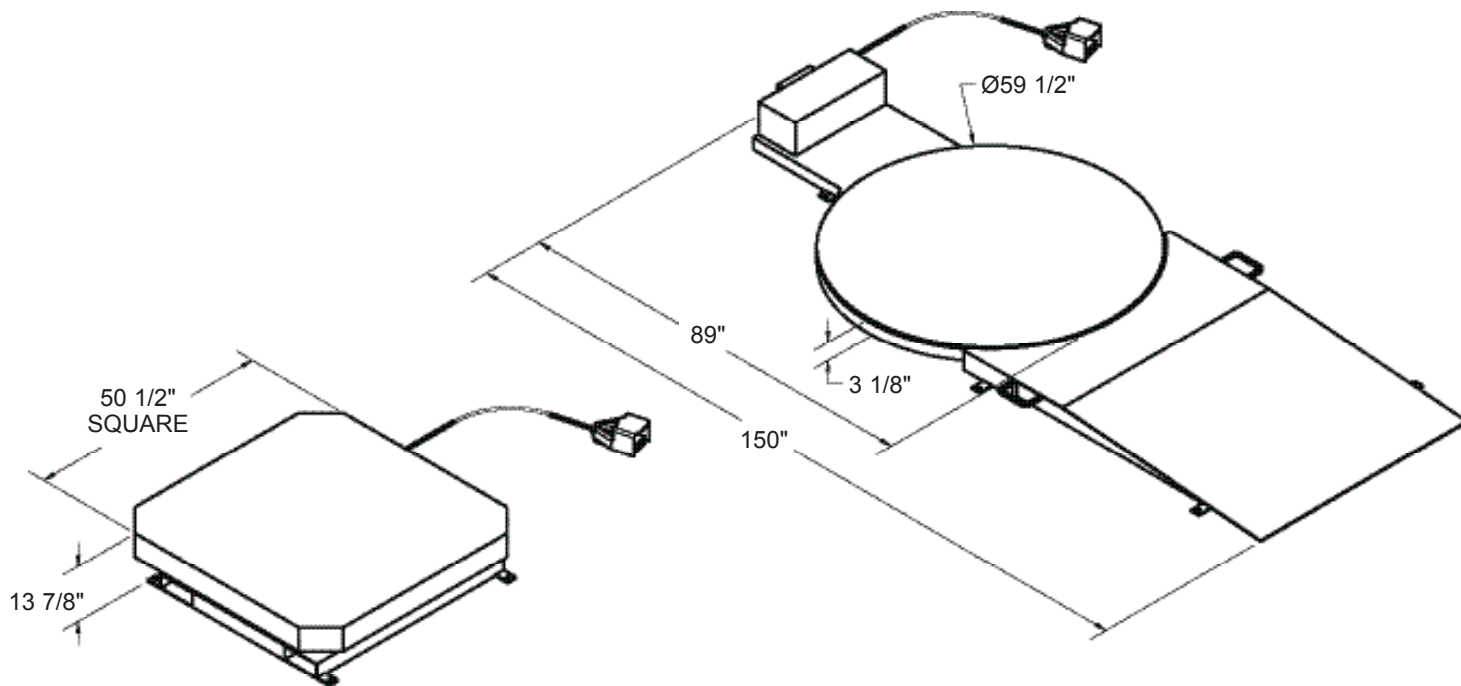

OPTIONS

Turntable System

- 50" x 90" Turntable
- 60" sq. Turntable (hp)
- Wrap-N-Weigh scale

Access ramps (LP only)

- Standard ramp
- Extended access ramp (powered pallet jack)
- Wrap-N-Weigh access ramp
- Wrap-N-Weigh extended ramp (powered pallet jack)

SPECIFICATIONS

Power Requirements

Electrical Data

- 120V, 1Ph, 60Hz, 10A
- Foot pedal control

Film Delivery System

- Hand wrapper

Approximate Shipping Weight

- HP: 560 lbs.
- LP: 650 lbs.